

6

5

4

3

2

1

Item	Name	Quantity	Part number
1	Table Top	1	LIA-CT-01
2	Leg	2	LIA-CT-02
3	Leg 2	2	LIA-CT-03
4	Long Rail	2	LIA-CT-04
5	Short Rail	2	LIA-CT-05
6	Z-Clip Furniture Connector Bracket	12	FHZC-01
7	Wood Screw	12	FHWS-M4-30

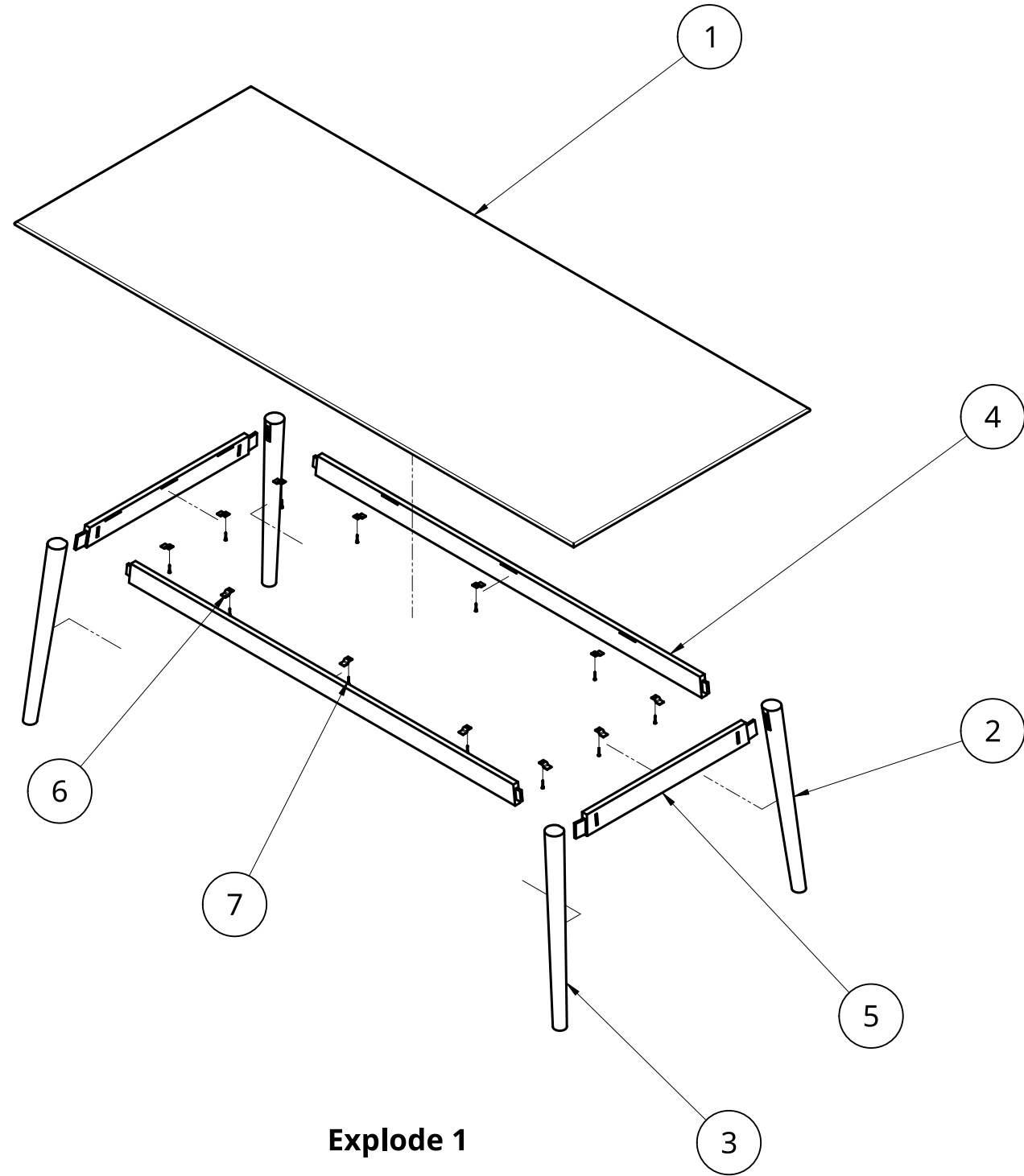

Explode 1

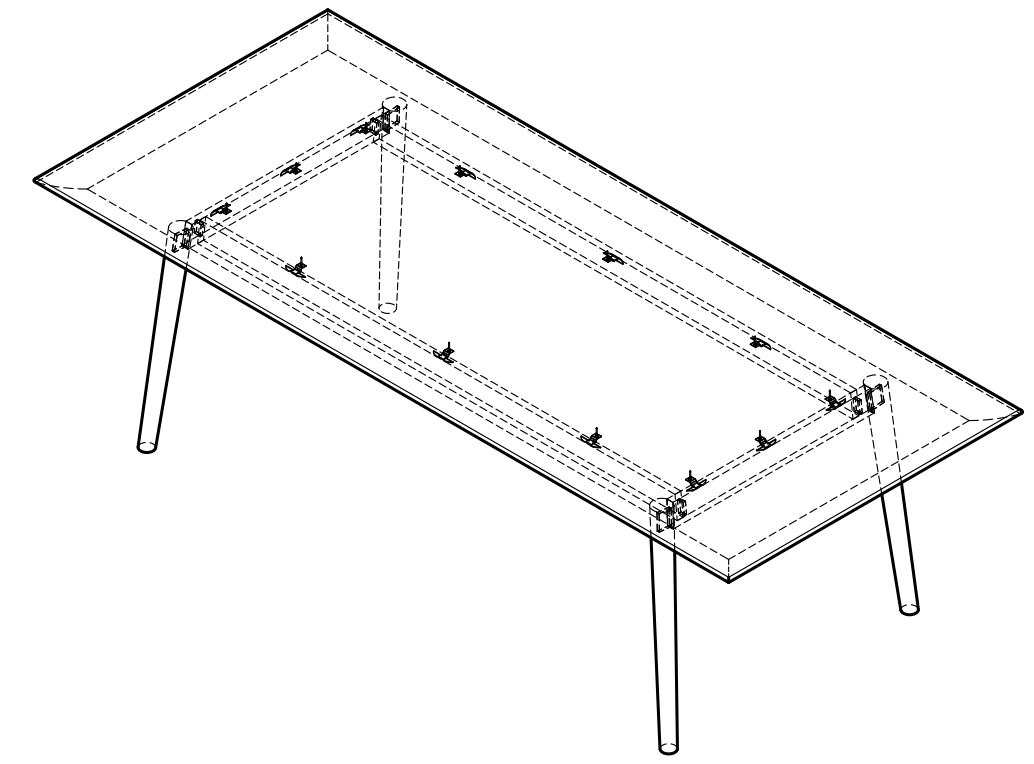

Isometric



NOTES

MATERIAL

FINISH

UNLESS OTHERWISE SPECIFIED,  
DIMENSIONS ARE IN MILLIMETERS

ANGULAR = ± °

SURFACE FINISH

DO NOT SCALE DRAWING

BREAK ALL SHARP EDGES AND  
REMOVE BURRS

	NAME	SIGNATURE	DATE
DRAWN	CRAIG VAN DE RUIT		2023-03-03
APPROVED			

FIRST ANGLE PROJECTION

TITLE		LIA DINING ROOM TABLE - 8 SEATER	
		ASSEMBLY 1	
SIZE	DWG / PRT NO.	REV.	
A3	ASSEMBLY		
SCALE	WEIGHT	SHEET	1 of 6
1:20			

6

5

4

3

2

1

D

D

C

C

B

B

A

A

6

5

4

3

2

1

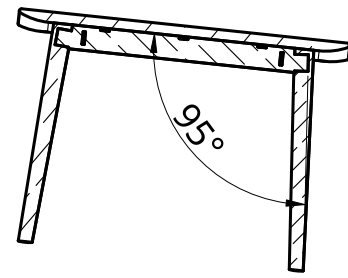

C - C

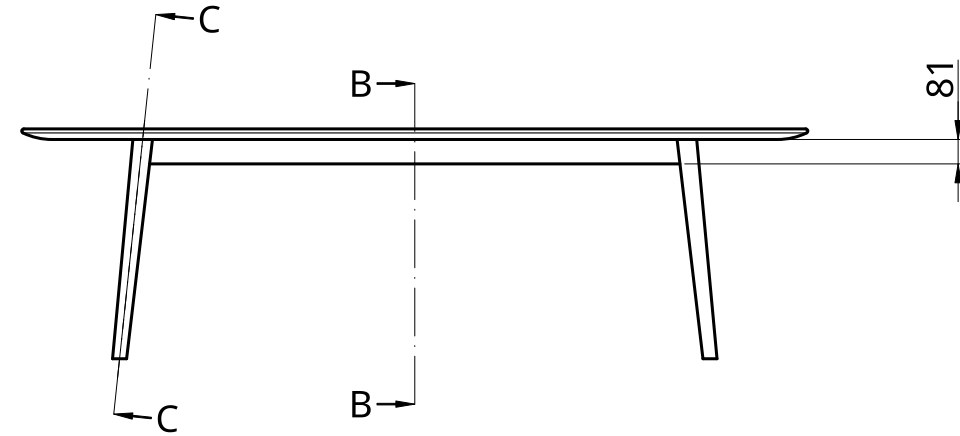

Front

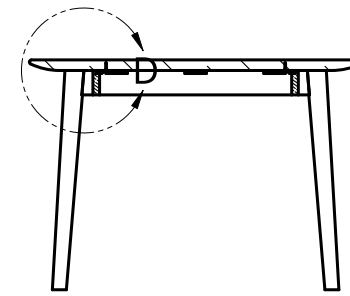

B - B

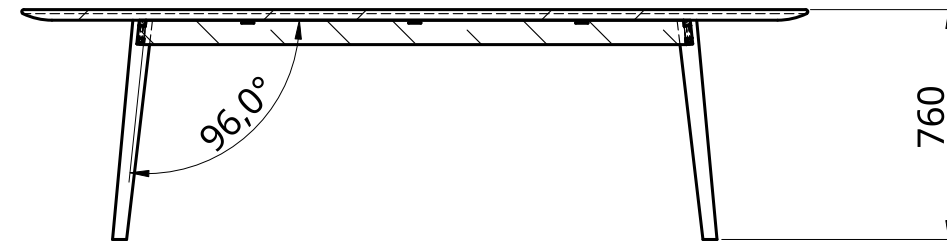

A - A

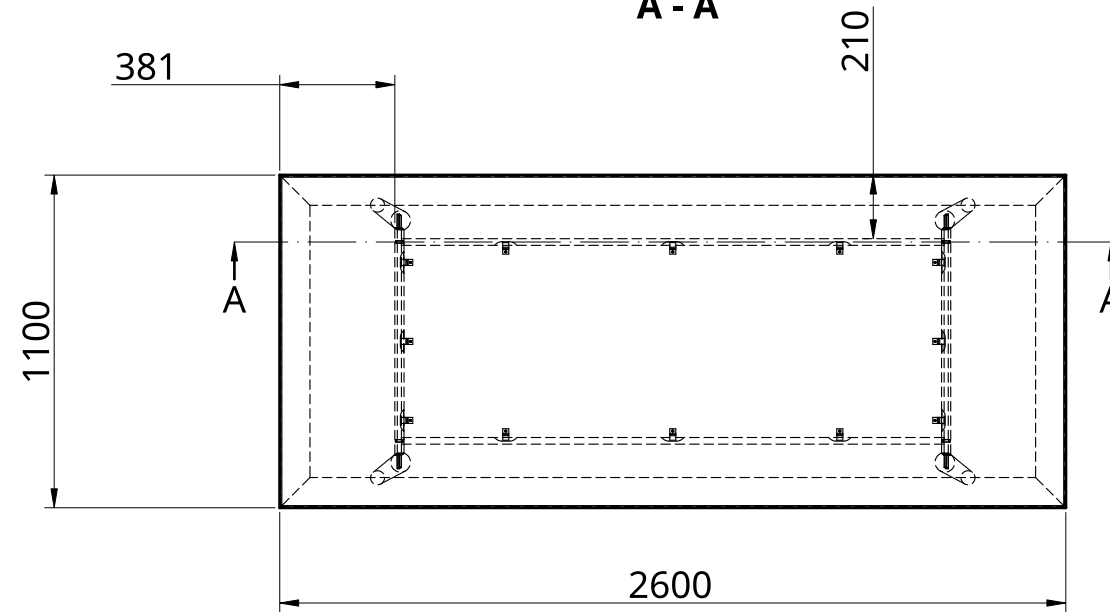

Top

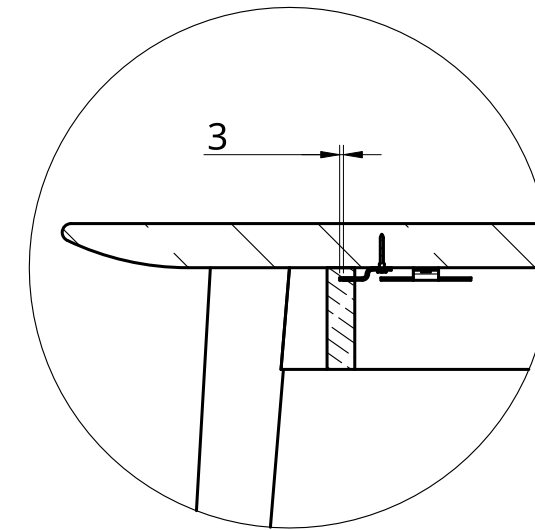

D  
1:6

D

D

C

C

B

B

A

A



NOTES

- USE FURNITURE Z-CLIPS AND STAINLESS STEEL SCREWS TO FASTEN THE TOP TO THE FRAME OR SIMILAR METHOD TO ALLOW FOR MOVEMENT OF THE TOP.
- LONG RAILS TO RAILS JOINT TO BE THRU TENONED AND WEDGED TO CREATE A DOVETAILED TENON.
- CROSS DOWEL LEG TO RAIL JOINTS USING 8MM DOWELS OF THE SAME TIMBER
- ALL JOINTS TO HAVE A GOOD FIT, GLUED WITH A HIGH QUALITY PVA WOOD GLUE AND CLAMPED FOR THE REQUIRED DURATION.

MATERIAL

LOCAL HARDWOOD

UNLESS OTHERWISE SPECIFIED, DIMENSIONS ARE IN MILLIMETERS

ANGULAR = ± °

SURFACE FINISH

DO NOT SCALE DRAWING

BREAK ALL SHARP EDGES AND REMOVE BURRS

FINISH

SAND THRU 60-220 GRIT  
 FINISH CLEAR MATT SUCH AS  
 OSMO 3044 RAW FOR PALE TIMBERS  
 OSMO 3062 FOR OTHERS

NAME

CRAIG VAN DE RUIT

SIGNATURE

DATE

2023-03-03

TITLE

LIA DINING ROOM TABLE - 8 SEATER  
 ASSEMBLY 1

APPROVED

FIRST ANGLE PROJECTION

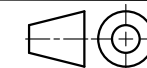

SIZE  
A3

DWG / PRT NO.

ASSEMBLY

REV.

SCALE 1:25

WEIGHT

SHEET

2 of 6

6

5

4

3

2

1

6

5

4

3

2

1

D

D



Front



Left

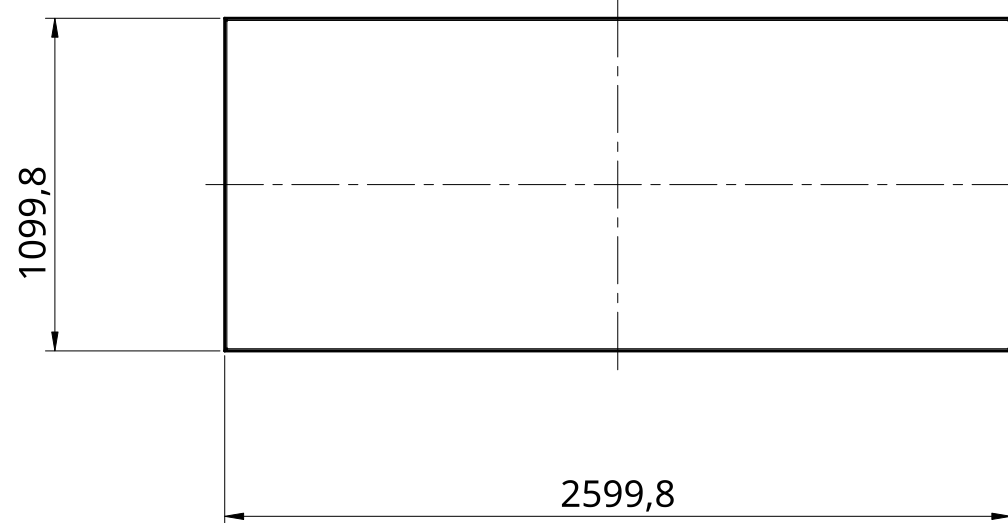

Top

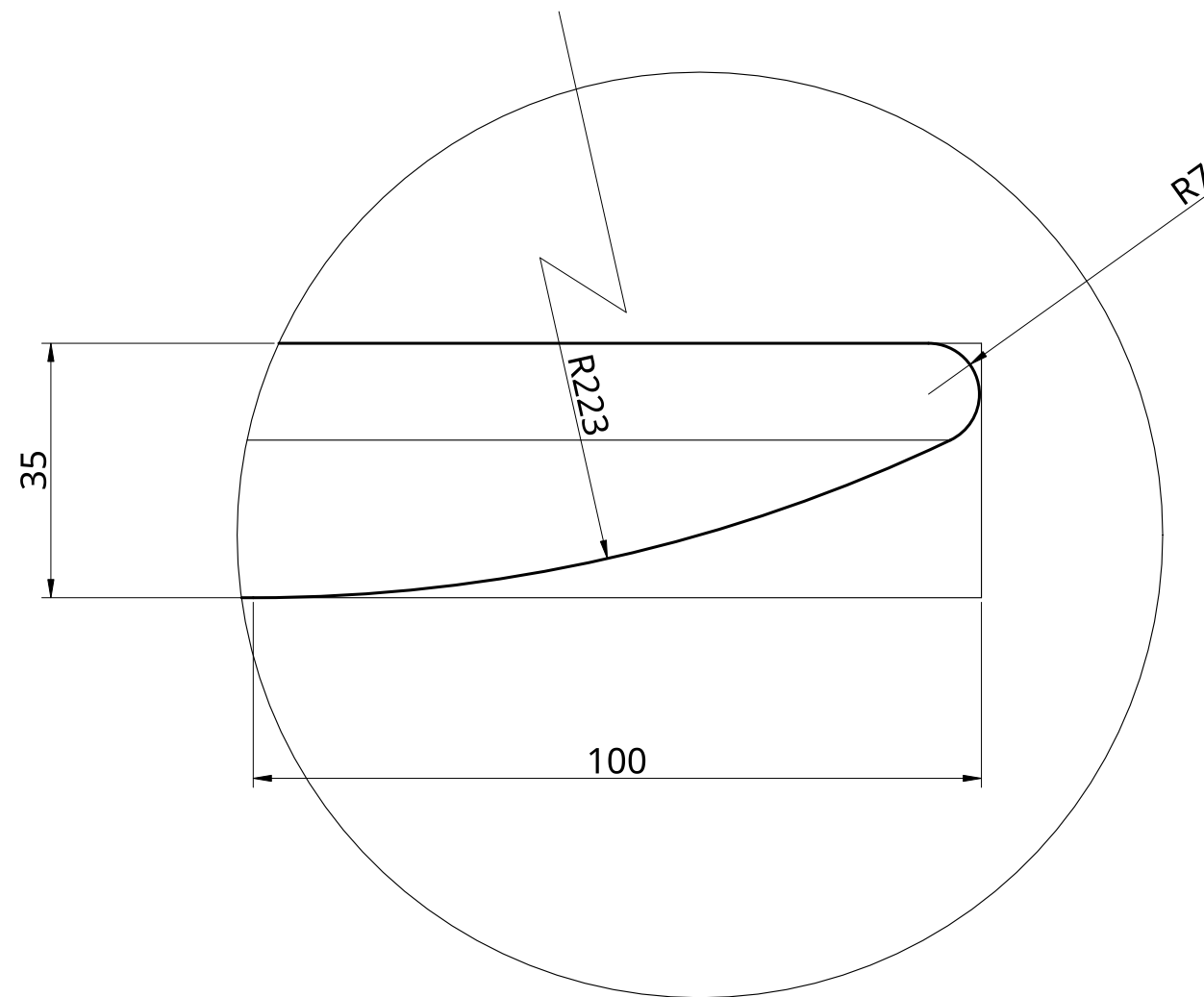

E  
1:1

B

B

C

C

A

A



NOTES

IT WOULD REQUIRE VERY SPECIALIST TOOLING TO CUT THE EDGE PROFILE. IF TOOLING NOT FEASIBLE PLANE BY HAND USING THE 1:1 SCALE DRAWING AS A TEMPLATE.

MATERIAL

LOCAL HARDWOOD

FINISH

UNLESS OTHERWISE SPECIFIED, DIMENSIONS ARE IN MILLIMETERS

ANGULAR = ± °

SURFACE FINISH

DO NOT SCALE DRAWING

BREAK ALL SHARP EDGES AND REMOVE BURRS

	NAME	SIGNATURE	DATE
DRAWN	CRAIG VAN DE RUIT		2023-03-03
APPROVED			

TITLE  
LIA DINING ROOM TABLE - 8 SEATER  
TABLE TOP

FIRST ANGLE PROJECTION

SIZE <b>A3</b>	DWG / PRT NO. <b>LIA-CT-01</b>	REV.
SCALE 1:25	WEIGHT	SHEET 3 of 6

6

5

4

3

2

1

6

5

4

3

2

1

D

D

C

C

B

B

A

A

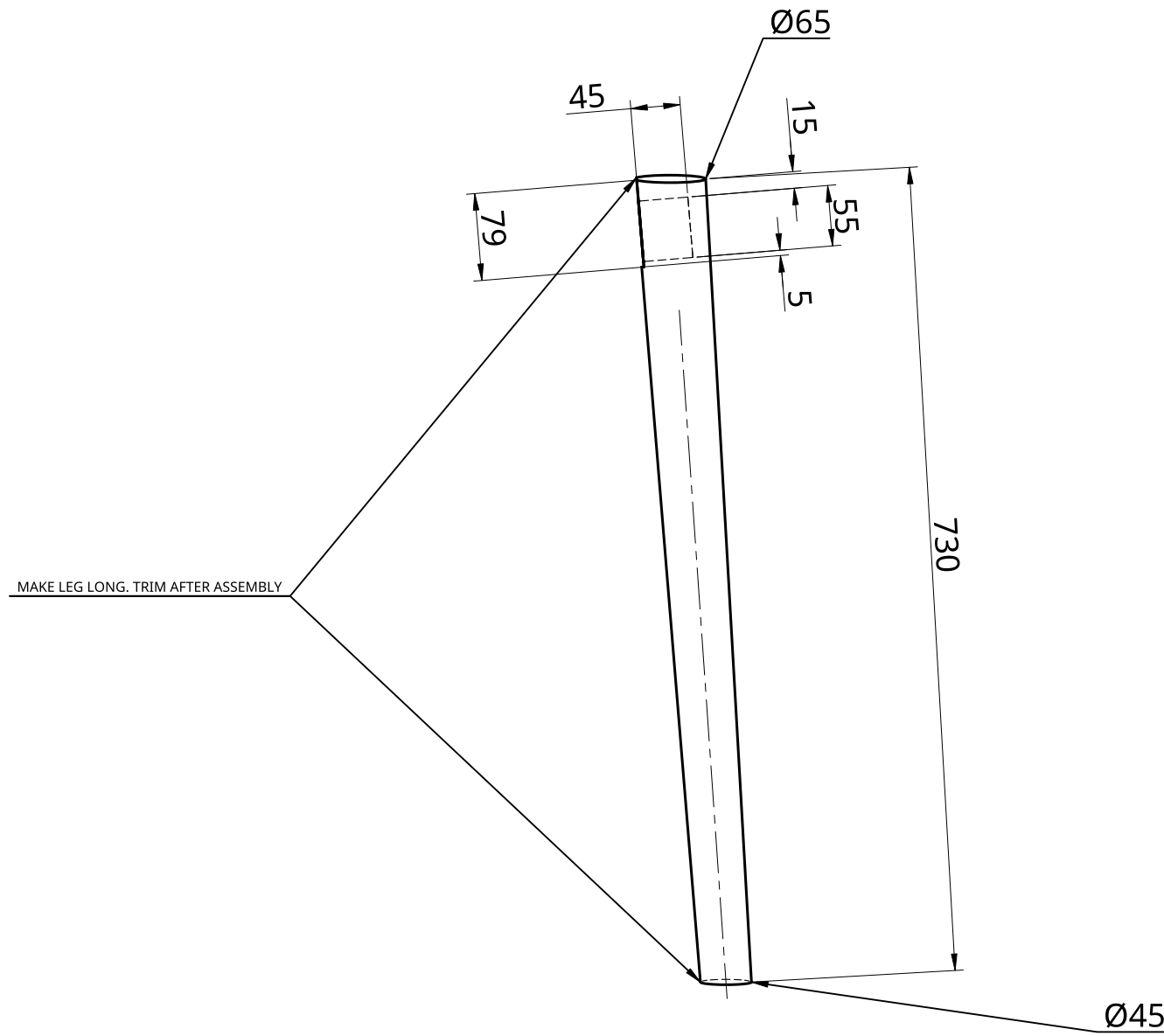

Normal to Short Rail

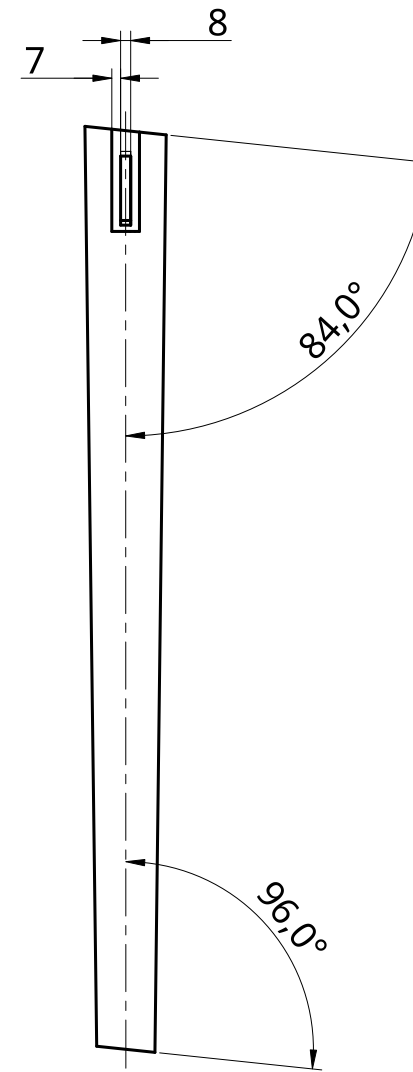

Left

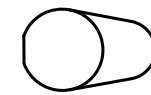

Top



NOTES

LEG 2 IS A MIRROR OF LEG 1 AFTER TRIMMING. HOWEVER PRIOR TO TRIMMING MAKE QTY 4 LEGS THEN TRIM AFTER ASSEMBLY

MATERIAL

LOCAL HARDWOOD

FINISH

UNLESS OTHERWISE SPECIFIED, DIMENSIONS ARE IN MILLIMETERS

ANGULAR = ± °

SURFACE FINISH

DO NOT SCALE DRAWING

BREAK ALL SHARP EDGES AND REMOVE BURRS

	NAME	SIGNATURE	DATE
DRAWN	CRAIG VAN DE RUIT		2023-03-03
APPROVED			

TITLE

LIA DINING ROOM TABLE - 8 SEATER  
LEG

SIZE  
A3

DWG /PRT NO.

LIA-CT-02

REV.

SCALE 1:6

WEIGHT

SHEET

4 of 6

6

5

4

3

2

1

6

5

4

3

2

1

D

D

C

C

B

B

A

A

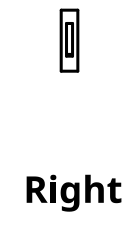
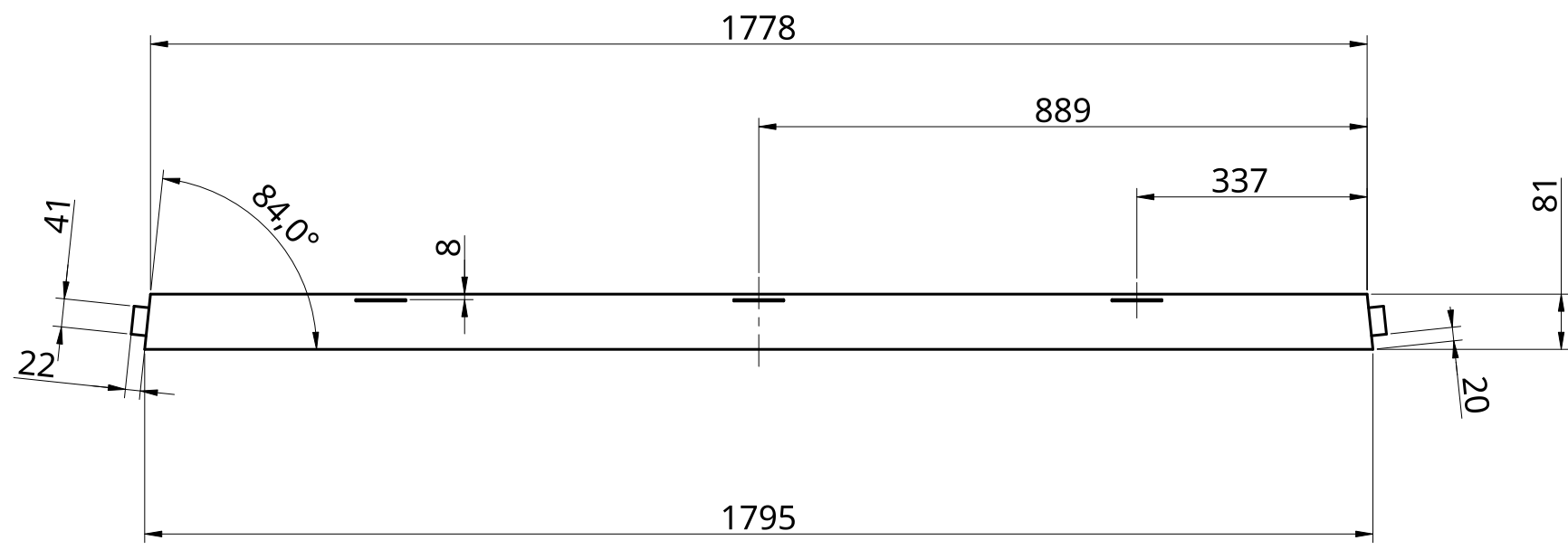

Right

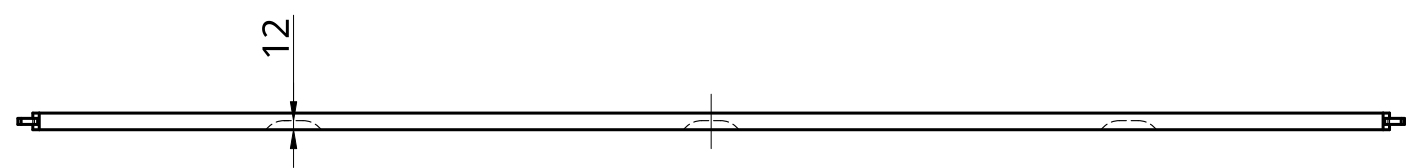

Top

NOTES

MATERIAL	LOCAL HARDWOOD
FINISH	

UNLESS OTHERWISE SPECIFIED,  
DIMENSIONS ARE IN MILLIMETERS

ANGULAR = ± °

SURFACE FINISH

DO NOT SCALE DRAWING

BREAK ALL SHARP EDGES AND REMOVE BURRS

	NAME	SIGNATURE	DATE
DRAWN	CRAIG VAN DE RUIT		2023-03-03
APPROVED			

FIRST ANGLE PROJECTION

TITLE		LIA DINING ROOM TABLE - 8 SEATER LONG RAIL	
SIZE	DWG / PRT NO.	LIA-CT-04	
SCALE	1:10	WEIGHT	
SHEET		5 of 6	



6

5

4

3

2

1

D

D

C

C

B

B

A

A

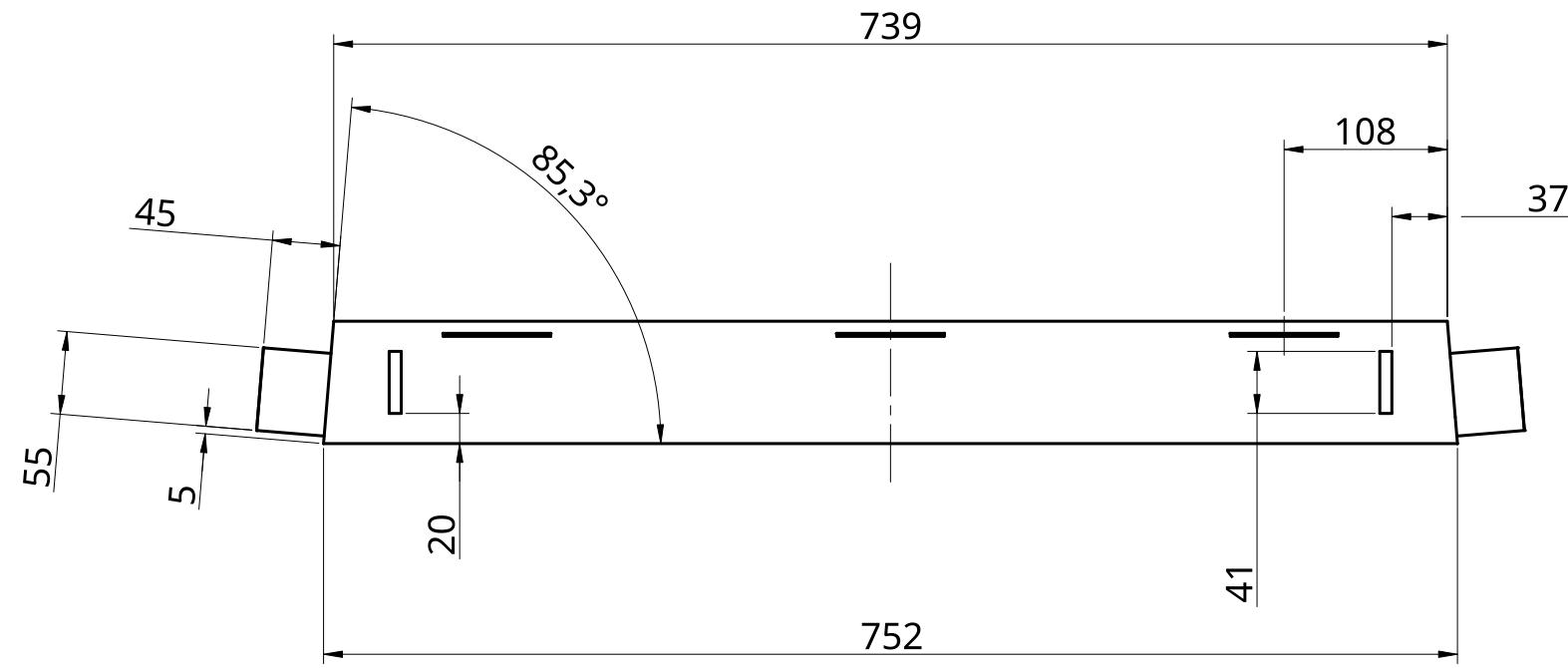

Normal Rail Back

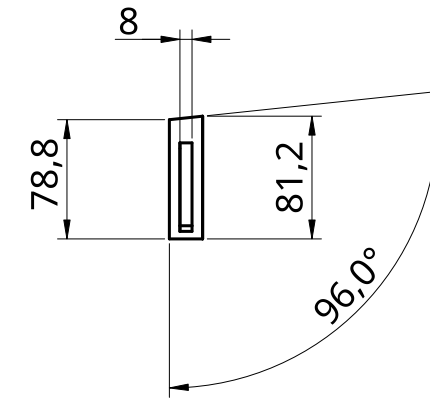

Left

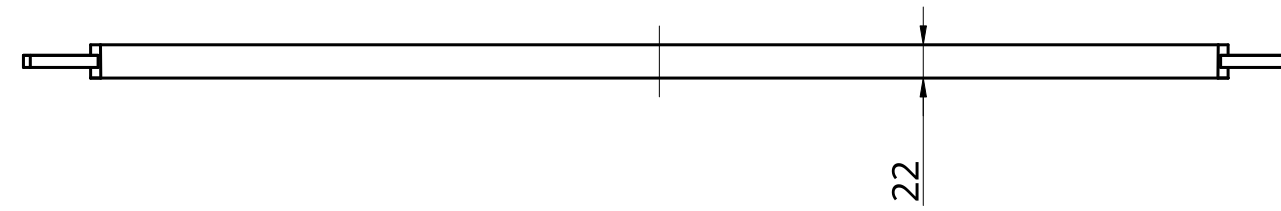

Top



NOTES

MATERIAL  
LOCAL HARDWOOD

UNLESS OTHERWISE SPECIFIED,  
DIMENSIONS ARE IN MILLIMETERS  
ANGULAR = ±°

DRAWN

NAME  
CRAIG VAN DE RUIT

SIGNATURE

DATE  
2023-03-03

TITLE

LIA DINING ROOM TABLE - 8 SEATER  
SHORT RAIL

FINISH

SURFACE FINISH

APPROVED

FIRST ANGLE PROJECTION

SIZE  
A3

DWG / PRT NO.

LIA-CT-05

REV.

DO NOT SCALE DRAWING

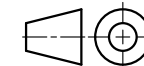

SCALE  
1:5

WEIGHT

SHEET

6 of 6

BREAK ALL SHARP EDGES AND  
REMOVE BURRS

6

5

4

3

2

1