

6

5

4

3

2

1

Item	Name	Quantity	Part number
1	Table Top	1	LIA-CT-01
2	Leg	2	LIA-CT-02
3	Leg 2	2	LIA-CT-03
4	Long Rail	2	LIA-CT-04
5	Short Rail	2	LIA-CT-05
6	Z-Clip Furniture Connector Bracket	10	FHZC-01
7	Wood Screw	10	FHWS-M4-16

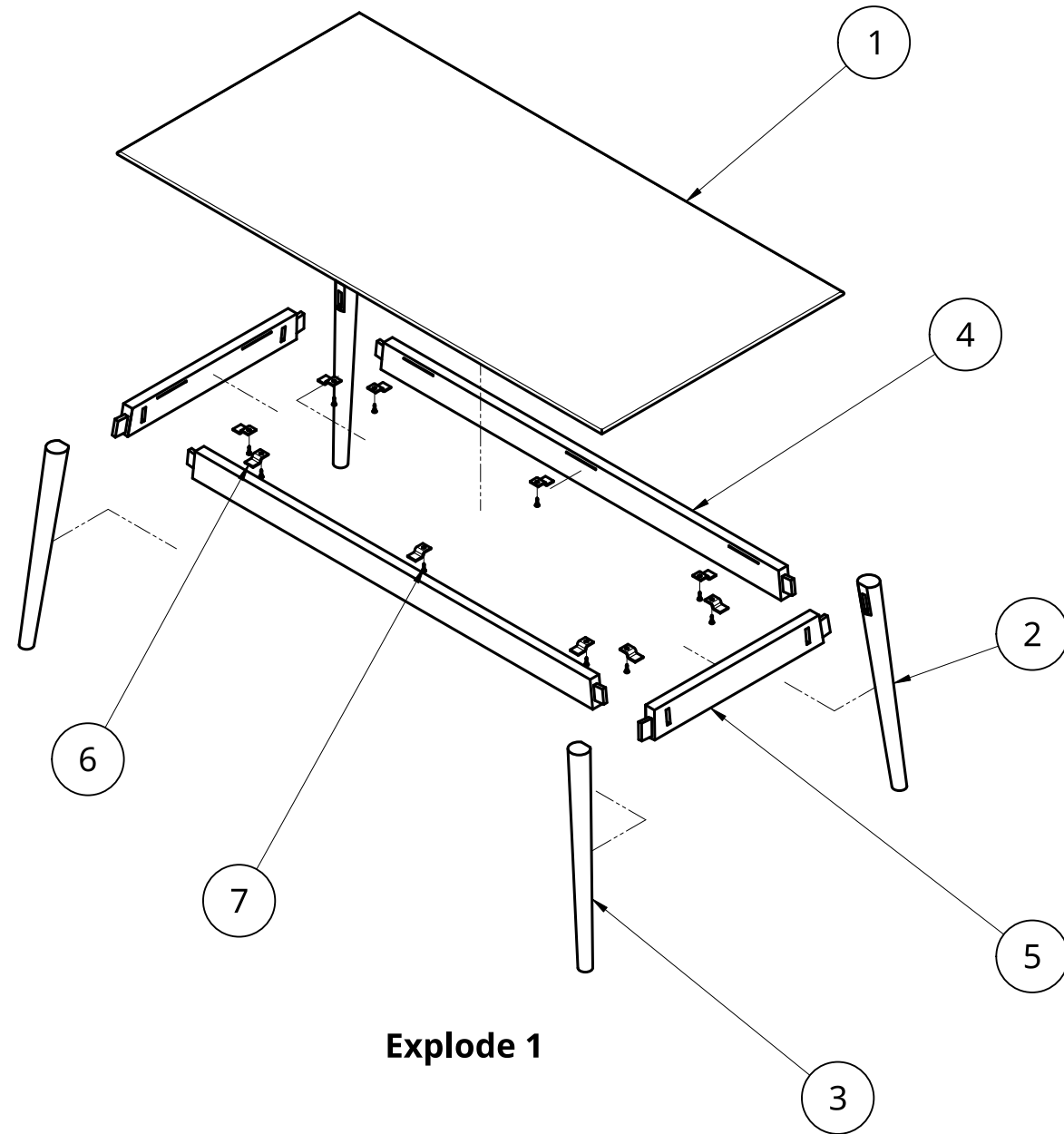

Explode 1

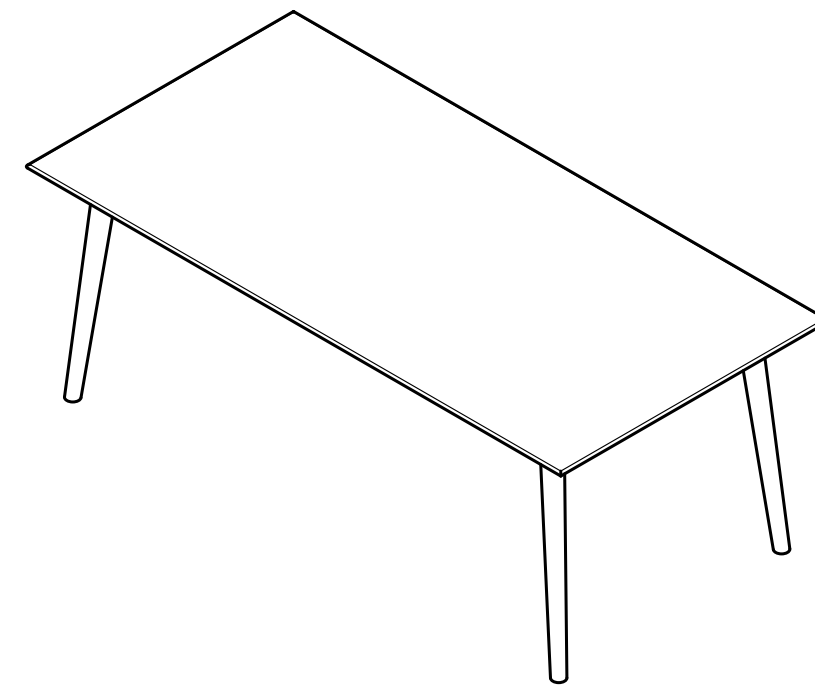

Isometric

D

D

C

C

B

B

A

A



NOTES

MATERIAL

UNLESS OTHERWISE SPECIFIED,
DIMENSIONS ARE IN MILLIMETERS

ANGULAR = ± °

FINISH

SURFACE FINISH

DO NOT SCALE DRAWING

BREAK ALL SHARP EDGES AND
REMOVE BURRS

	NAME	SIGNATURE	DATE	TITLE
DRAWN	CRAIG VAN DE RUIT		2023-03-03	LIA COFFEE TABLE ASSEMBLY
APPROVED				

FIRST ANGLE PROJECTION

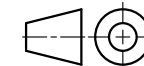

SIZE	DWG / PRT NO.	REV.
A3	GENERAL ASSEMBLY	
SCALE 1:12	WEIGHT	SHEET 1 of 6

6

5

4

3

2

1

6

5

4

3

2

1

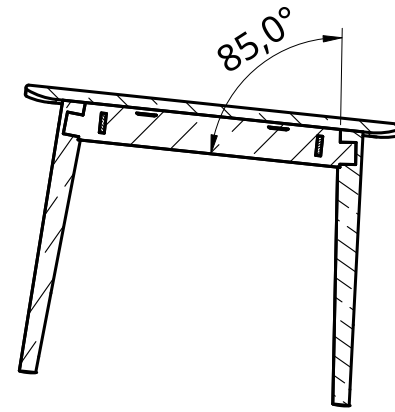

C - C

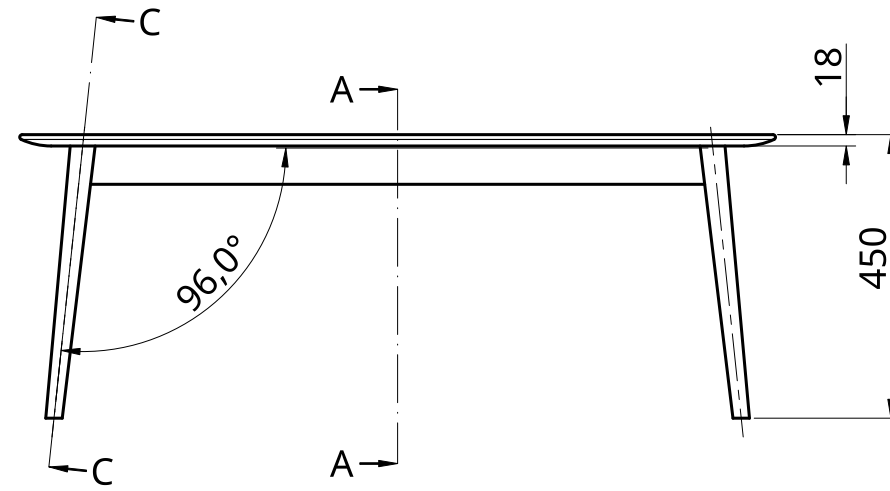

Front

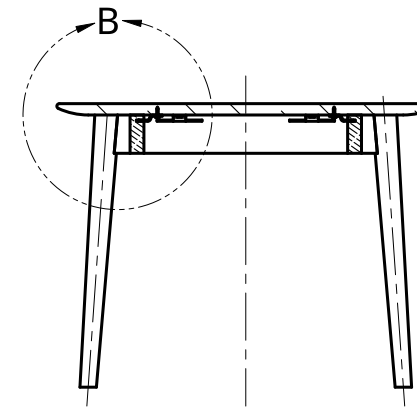

A - A

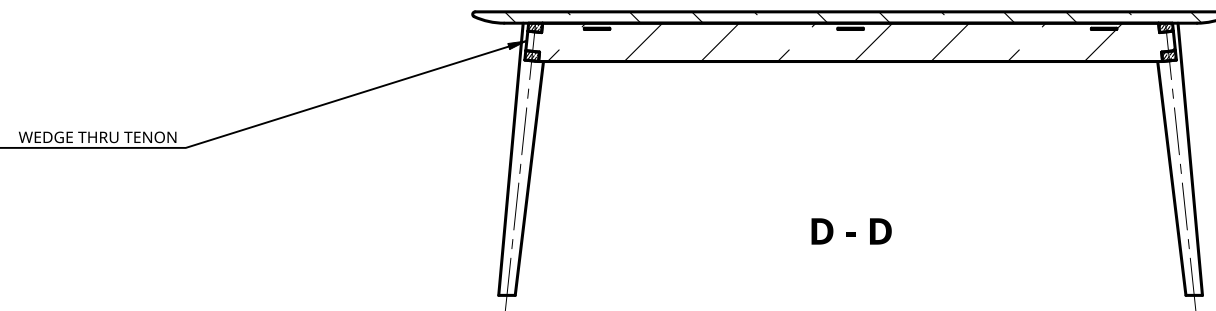

D - D

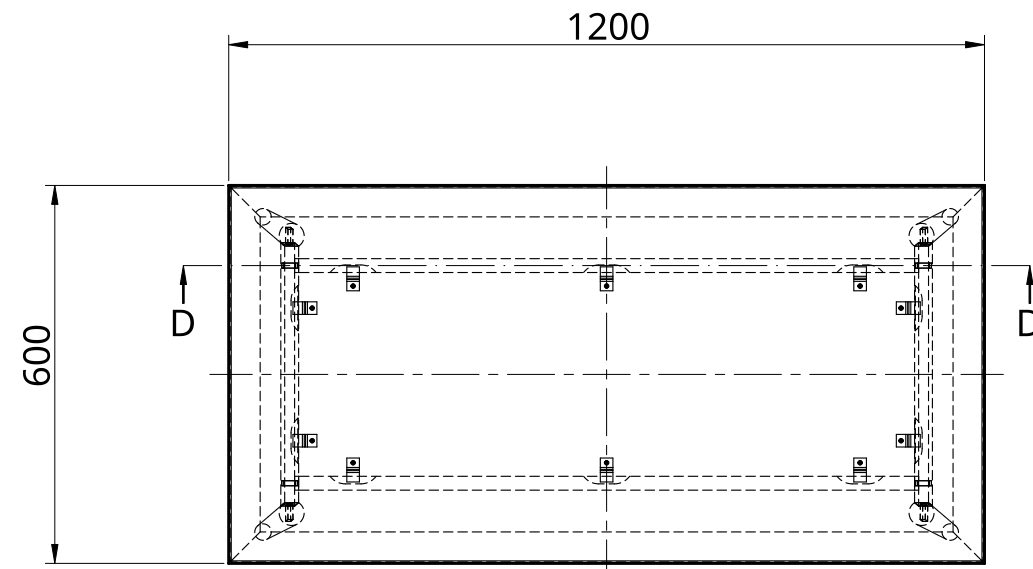

Top

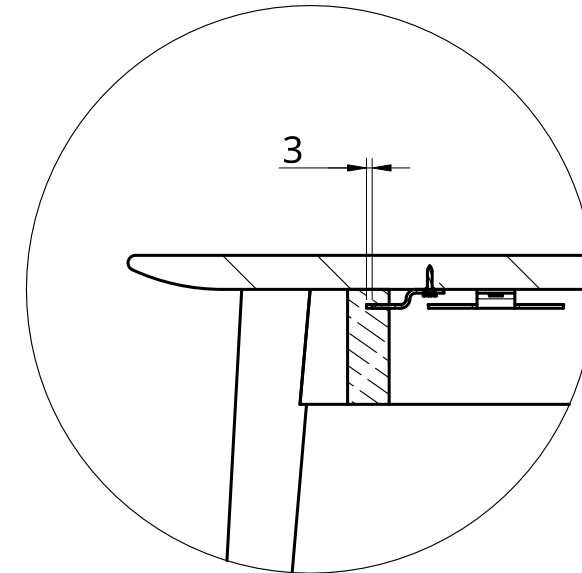

B
1:4

A



NOTES

- CROSS DOWEL LEG RAIL JOINTS WITH 6MM DOWELS OF THE SAME TIMBER
- ALL JOINTS TO HAVE A GOOD FIT, GLUED WITH A HIGH QUALITY PVA WOOD GLUE AND CLAMPED FOR REQUIRED DURATION.
- TOP TO BE FASTENED TO BASE FRAME USING STEEL Z-CLIP BRACKETS AND STAINLESS STEEL WOOD SCREWS AS DRAWN OR SIMILAR METHOD TO ALLOW WOOD MOVEMENT ACROSS THE GRAIN
- RAIL TO RAIL JOINTS TO BE THRU TENONED. RELIEVE OUTSIDE MORTICE AND WEDGE TO CREATE A DOVETAILED TENON.

MATERIAL

LOCAL HARDWOOD

FINISH

SANDTHRU 60-220 GRIT
FINISH CLEAR MATT SUCH AS
OSMO 3044 RAW FOR PALE TIMBERS
OSMO 3062 FOR OTHERS

UNLESS OTHERWISE SPECIFIED,
DIMENSIONS ARE IN MILLIMETERS

ANGULAR = ± °

SURFACE FINISH

DO NOT SCALE DRAWING

BREAK ALL SHARP EDGES AND REMOVE BURRS

	NAME	SIGNATURE	DATE	TITLE
DRAWN	CRAIG VAN DE RUIT		2023-03-03	LIA COFFEE TABLE ASSEMBLY
APPROVED				

FIRST ANGLE PROJECTION

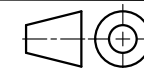

SIZE
A3

DWG / PRT NO.

GENERAL ASSEMBLY

REV.

SCALE 1:12

VOLUME AND SURFACE AREA
0.1749M3 2.183M2

SHEET 2 of 6

6

5

4

3

2

1

A

6

5

4

3

2

1

D

D

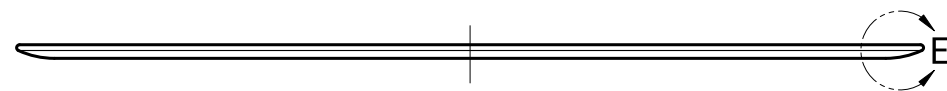

Front



Left

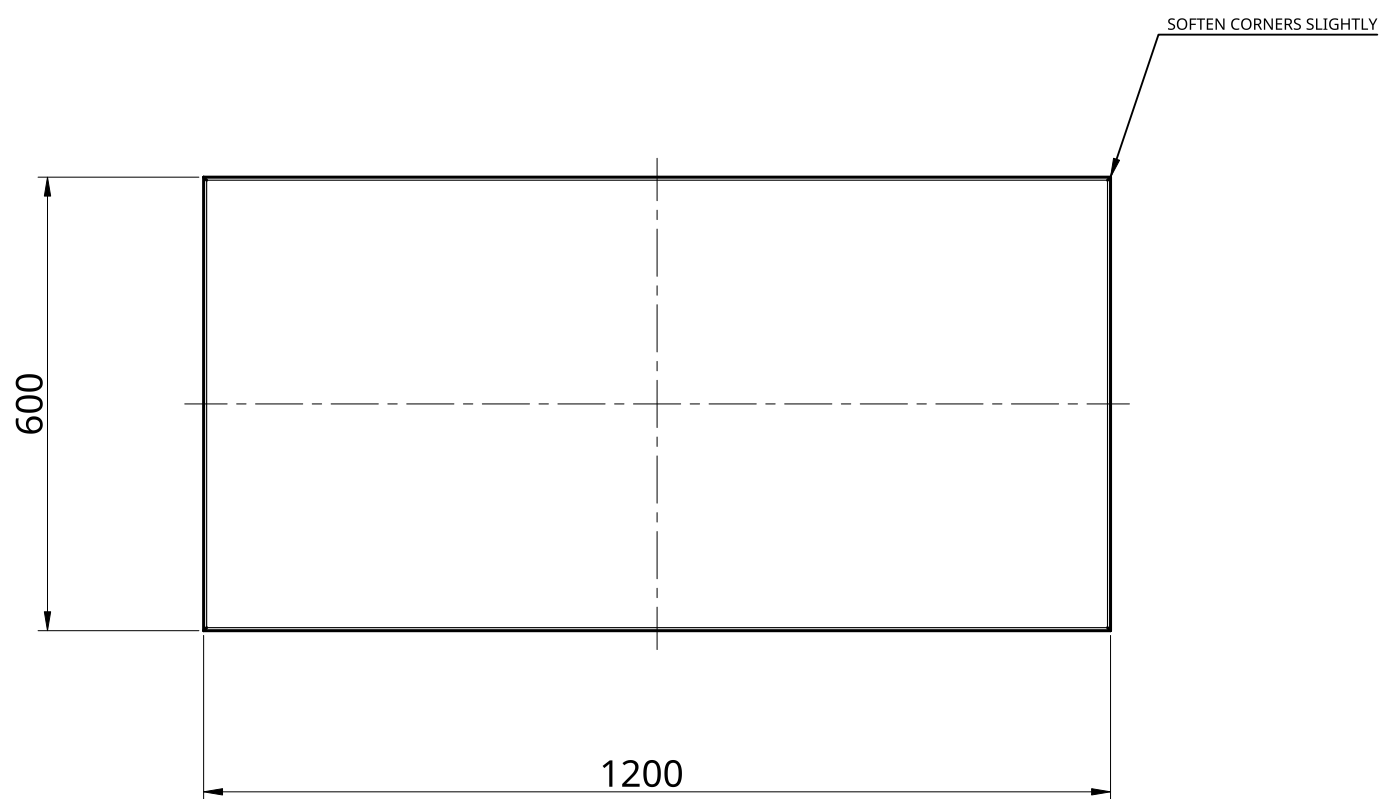

Top

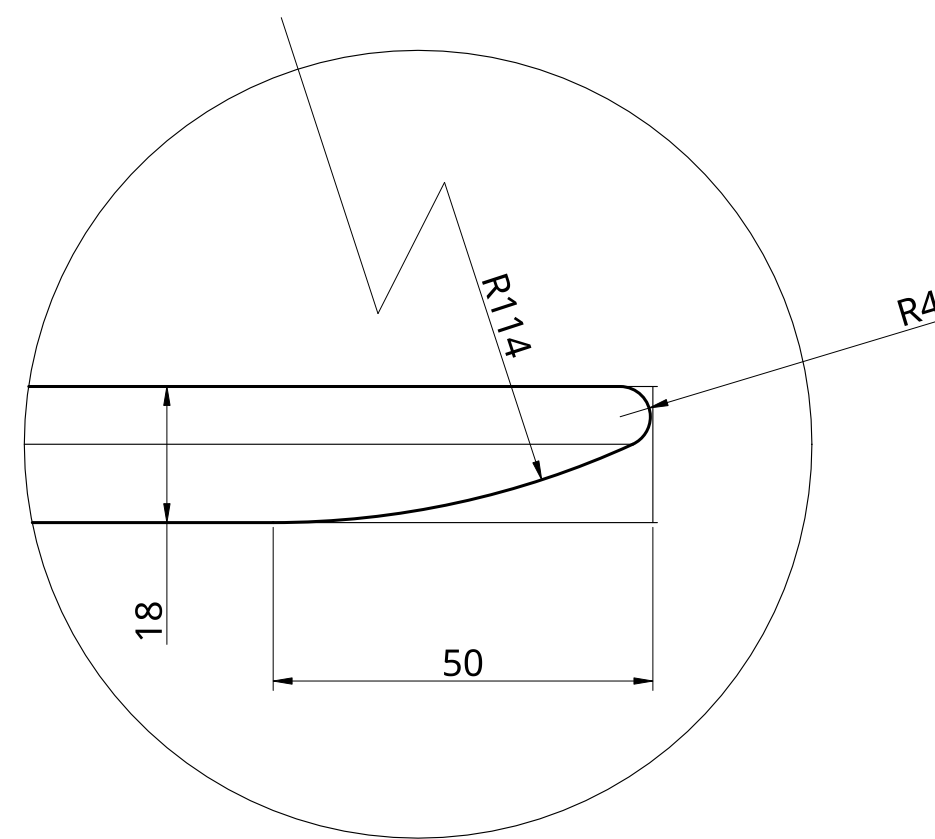

E
1:1

B

B

C

C

A

A



NOTES

IT WOOD REQUIRE VERY SPECIALIST TOOLING TO CUT EDGE TREATMENT
IF TOOLING NOT AVAILABLE HAND PLANE USING 1:1 SCALE PROFILE AS
A TEMPLATE

MATERIAL

UNLESS OTHERWISE SPECIFIED,
DIMENSIONS ARE IN MILLIMETERS

ANGULAR = ± °

FINISH

SURFACE FINISH

DO NOT SCALE DRAWING

BREAK ALL SHARP EDGES AND
REMOVE BURRS

	NAME	SIGNATURE	DATE	TITLE
DRAWN	CRAIG VAN DE RUIT		2023-03-03	LIA COFFEE TABLE TABLE TOP
APPROVED				

FIRST ANGLE PROJECTION



SIZE	DWG /PRT NO.	REV.
A3	LIA-CT-01	
SCALE 1:10	WEIGHT	SHEET 3 of 6

6

5

4

3

2

1

6

5

4

3

2

1

D

D

C

C

B

B

A

A

MAKE LEG LONG. TRIM AFTER ASSEMBLY

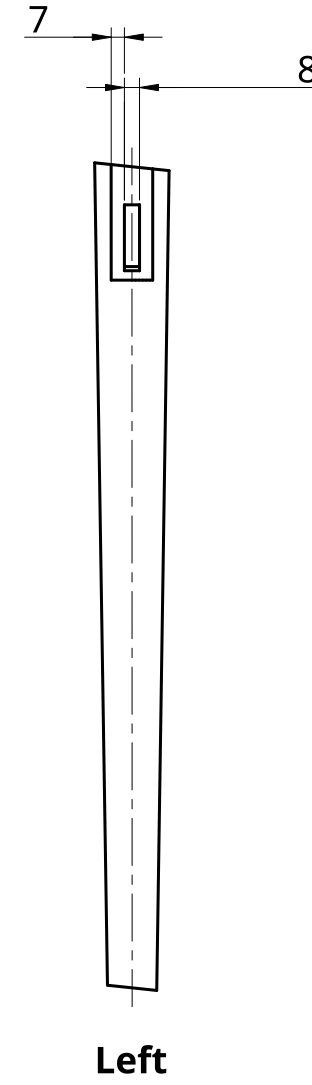
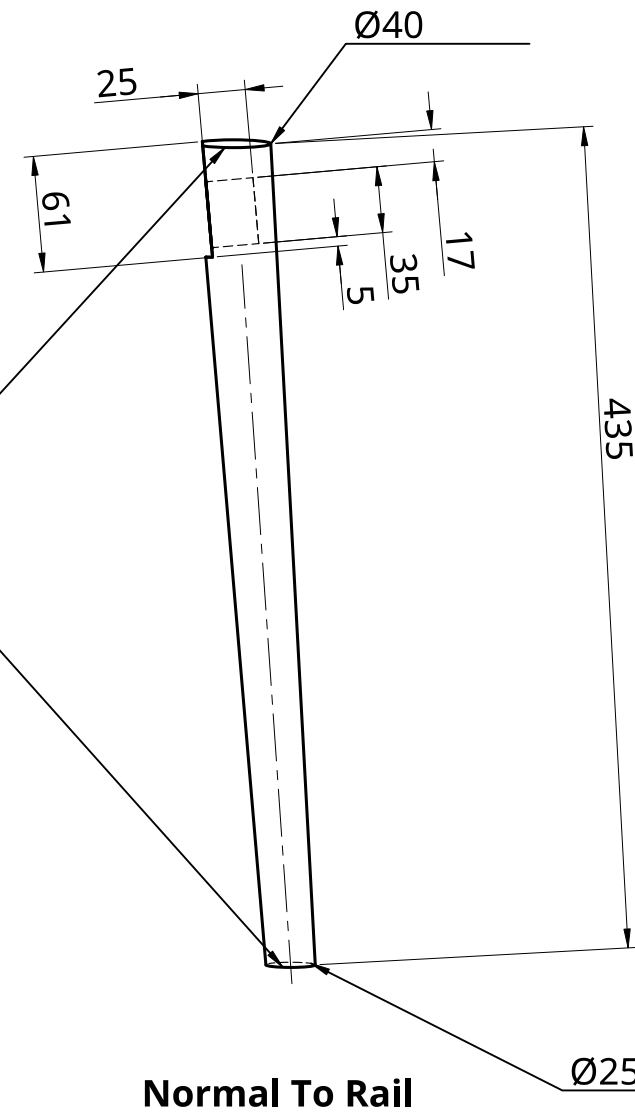

NOTES

LEG 2 IS A MIRROR OF LEG ONE BUT IN EFFECT IS THE SAME UNTIL TRIMMING AFTER ASSEMBLY. THUS MAKE QTY 4 LEGS AS DRAWN BUT LONG THEN TRIM AFTER ASSEMBLY

MATERIAL

LOCAL HARDWOOD

FINISH

UNLESS OTHERWISE SPECIFIED, DIMENSIONS ARE IN MILLIMETERS

ANGULAR = ± °

SURFACE FINISH

DO NOT SCALE DRAWING

BREAK ALL SHARP EDGES AND REMOVE BURRS

	NAME	SIGNATURE	DATE	TITLE
DRAWN	CRAIG VAN DE RUIT		2023-03-03	LIA COFFEE TABLE LEG
APPROVED				

FIRST ANGLE PROJECTION

SIZE	DWG / PRT NO.		REV.
A3	LIA-CT-02		
SCALE	WEIGHT	SHEET	
1:4		4 of 6	

6

5

4

3

2

1

6

5

4

3

2

1

D

D

C

C

B

B

A

A

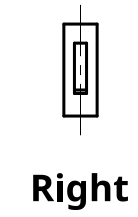
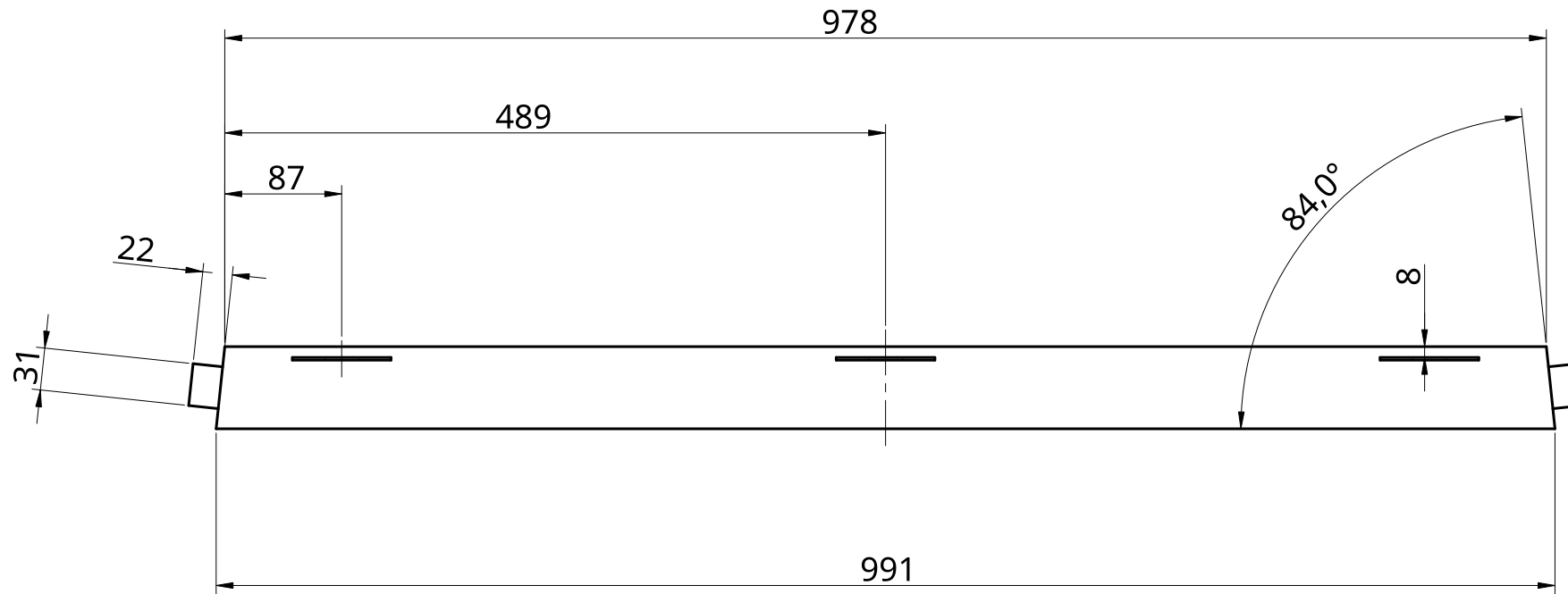

Back

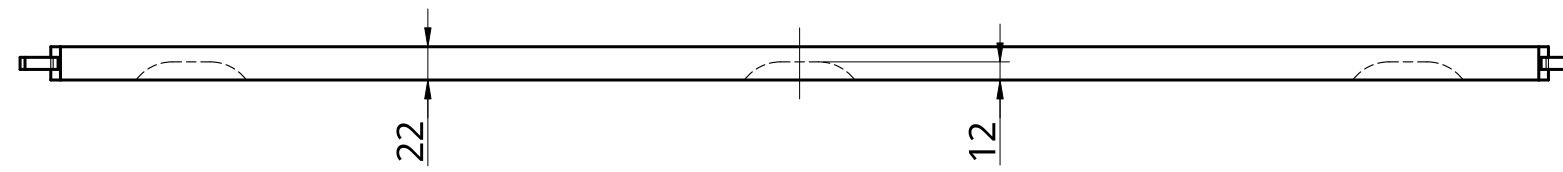

Top

NOTES

MATERIAL

UNLESS OTHERWISE SPECIFIED,
DIMENSIONS ARE IN MILLIMETERS

ANGULAR = ±°

SURFACE FINISH

DO NOT SCALE DRAWING

BREAK ALL SHARP EDGES AND
REMOVE BURRS

DRAWN

CRAIG VAN DE RUIT

SIGNATURE

DATE

2023-03-03

APPROVED

FIRST ANGLE PROJECTION

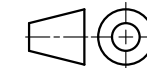

TITLE

LIA COFFEE TABLE
LONG RAIL

SIZE
A3

DWG /PRT NO.

LIA-CT-04

REV.

SCALE 1:5

WEIGHT

SHEET

5 of 6



6

5

4

3

2

1

6

5

4

3

2

1

D

D

C

C

B

B

A

A

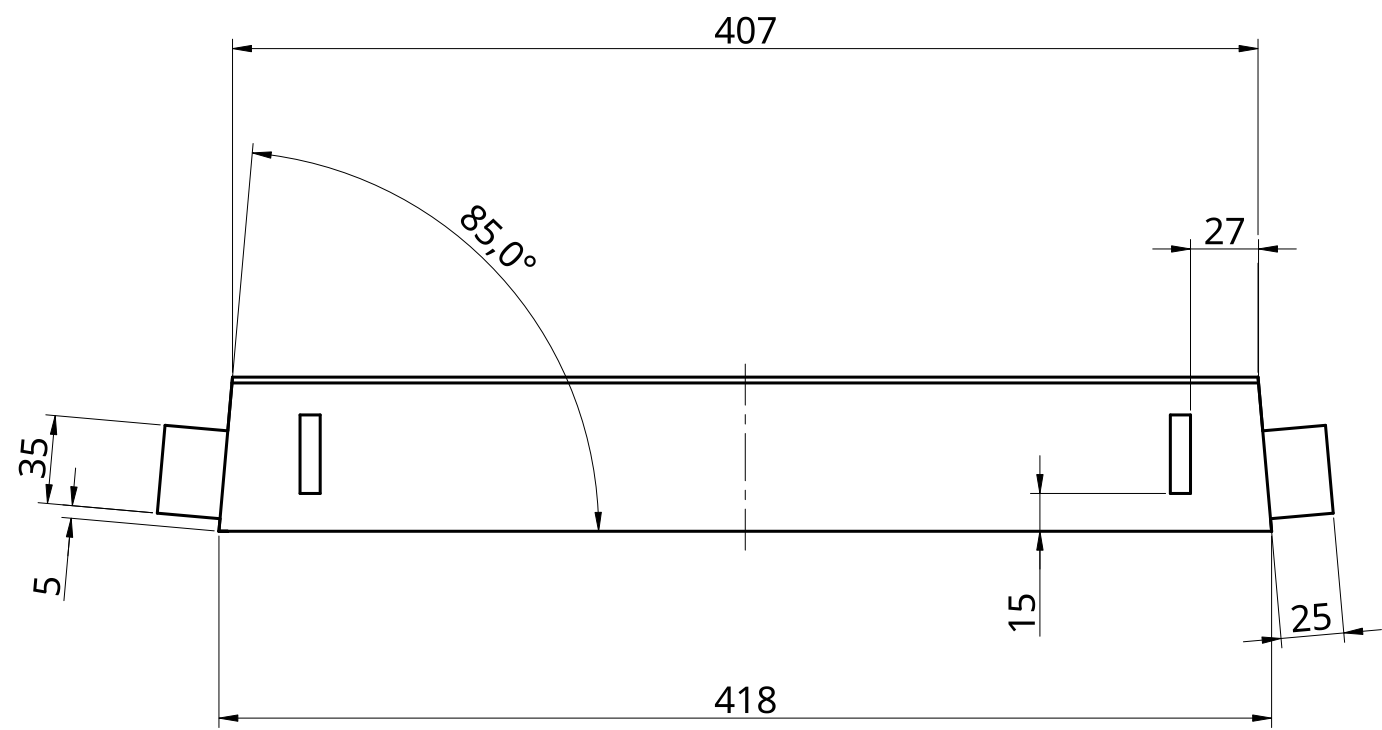

Normal To Rail

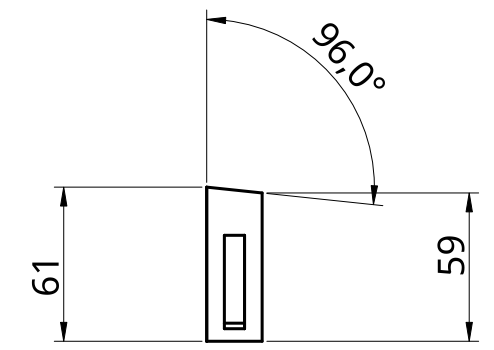

Left



Top



NOTES

MATERIAL
LOCAL HARDWOOD

FINISH

UNLESS OTHERWISE SPECIFIED,
DIMENSIONS ARE IN MILLIMETERS

ANGULAR = ± °

SURFACE FINISH

DO NOT SCALE DRAWING

BREAK ALL SHARP EDGES AND
REMOVE BURRS

	NAME	SIGNATURE	DATE	TITLE
DRAWN	CRAIG VAN DE RUIT		2023-03-03	LIA COFFEE TABLE SHORT RAIL
APPROVED				

FIRST ANGLE PROJECTION

SIZE	DWG /PRT NO.		REV.
A3	LIA-CT-05		
SCALE	WEIGHT	SHEET	
1:3		6 of 6	

6

5

4

3

2

1